



LAKE COUNTY 2026 Primary ELECTION TRAINING MANUAL

WELCOME POLL WORKERS

Lake County Board of Elections & Registration

Michelle R. Fajman	Director
Jessica F. Messler	Assistant Director
Jerry Schmitt	Election Administrator
Luis Aguilar	Assistant Election Administrator
Joel Rodriguez	Registration Administrator
Lori O'Dea	Assistant Registration Administrator
Andre Manzo	Chief Technician
James Oliver	Assistant Chief Technician

Election Board Members

Kevin C. Smith
Michael Brown
Mara Candelaria Reardon
John P. Reed
Charlene Foss-Eggemann



Mandatory

****INSPECTORS****

**PLEASE CALL ALL OF THE WORKERS
AND INVITE THEM TO SET UP YOUR
POLL LOCATION ON MONDAY.**

This isn't about needing help. This is about a bipartisan process.

ELECTION SUPPLIES

This Black Bag Contains ELECTION Supplies.

PLEASE VERIFY THE CONTENTS OF THIS BAG
BEFORE ELECTION MORNING

CONTACT THE ELECTION BOARD AT 219-755-3795 IF THE BAG HAS
MISSING SUPPLIES.

VOTING MACHINE TECHNICIAN NUMBERS ARE LISTED IN
THE BLACK BAG (BEFORE ELECTION DAY CALL 219-755-3845)

FOR ALL OTHER CONCERNS CONTACT 219-755-3795

MUST Post Sample Ballot, Voters' Rights, and Voting Instructions

Post Vote Here Signs, Stretch Rope from the entrance to voting room, 50ft full-length

Set up in this order (Important!)

1. Turn on Jet Pack/Mi-fi, Hotspot, or Cradle-point
2. Turn on the Poll Pad Printer
3. Turn on Poll Pad (keep cell phones away)

Make sure to have at least 1-2 feet of space between each unit.

Make Sure there is a Clear Path to all Voting Machines.

Only if Bipartisan Team is present, cut the red seal on Grey Case, turn on voting machine, print Zero Count. (Do this on Monday setting up and on Tuesday, Election morning A.M.) See page 11.

MEALS

Make sure you make arrangements for food during the day.

- Bring a lunch
- Have someone bring your lunch to the door
- Order takeout or a pizza

(Try to meet the delivery person at the door, they can't come in without credentials.)



MICROVOTE SUPPLIES

WHAT TO LOOK FOR

VOTING MACHINE CASE

Includes: 1. INFINITY VOTING MACHINE
2. VVPAT (BLACK BOX)

PRECINCT BAG

VOTING MACHINE PRINTER

POLL PAD PRINTER

POWER CORD FOR ALL PRINTERS

VOTING MACHINE PRINTER CABLE (Silver, Already Attached)

Two stylus pens and an Extra Roll of Paper for each Printer

DOUBLE TALK BOX & HEADPHONES

*PRECINCT ENVELOPE (Large WHITE Envelope)

START CARDS (Green)

VOTE CARDS (Blue)

TALLY CARDS(Red) (inside the Tally Envelope)

Note! Combined/Split precincts will have an encoder with charging Cable (See Encoder Manual in the Precinct Bag).



ON MONDAY START VOTING MACHINE SYSTEM
Only if the Bipartisan team is Present

CHECK LUGGAGE TAG

SET UP MACHINE

CUT RED SEALS

Only if Bipartisan Team is Present

PRINT ZERO TAPE

To Test Infinity Printer

CHECK BALLOT



NOTE: If a Bipartisan team is not present, check the luggage tag and set the machine on its legs then STOP. The rest will have to be done on Election Day morning.

1. Stand booth on side with wheels touching the floor, and pull legs out of their clips or use table, if available.
2. Rotate/Twist each leg to the right until it is locked in place
3. With assistance, stand booth up onto legs
4. Once booth is stable, open the lid



Twist leg to the right, until
it can no longer turn, to
lock into place



5. Feed power cord through starburst in the booth and plug into power strip or another electrical outlet. This will power on the VVPAT and voting machine.
6. If the voting machine did not power on, check the power switch on the top-side right of the voting machine (See page 13).
7. If needed, you can engage the stand on the bottom of the voting machine for a better viewing angle.



8. Remove the curtain rods clipped at the top of the booth lids.
9. Insert each curtain into the orange brackets by pressing them into the bracket firmly



MONDAY SETUP

only if the bipartisan team is present

10. Turn on the power switch on the voting panel. The power switch is located on the back of the voting panel, towards the right hand side.

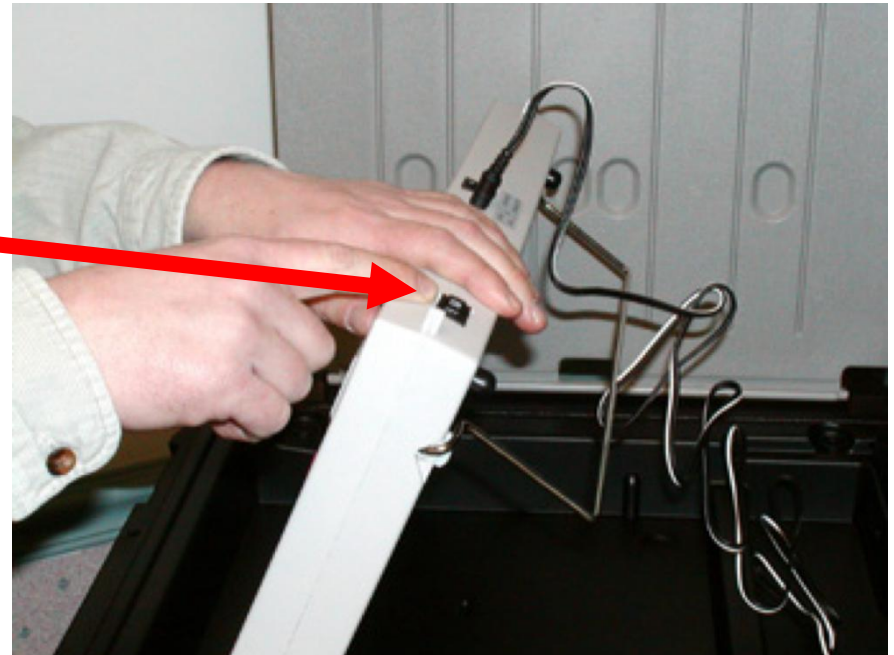

11. Press the red CAST VOTE button with no card inserted to verify the screen says the following:

- * **MODE: LOCKED**
- * **VOTES RECORDED: 0**
- * Date and Time are correct
- * Precinct Name: If you are a consolidated precinct your precinct name will say Multiple.

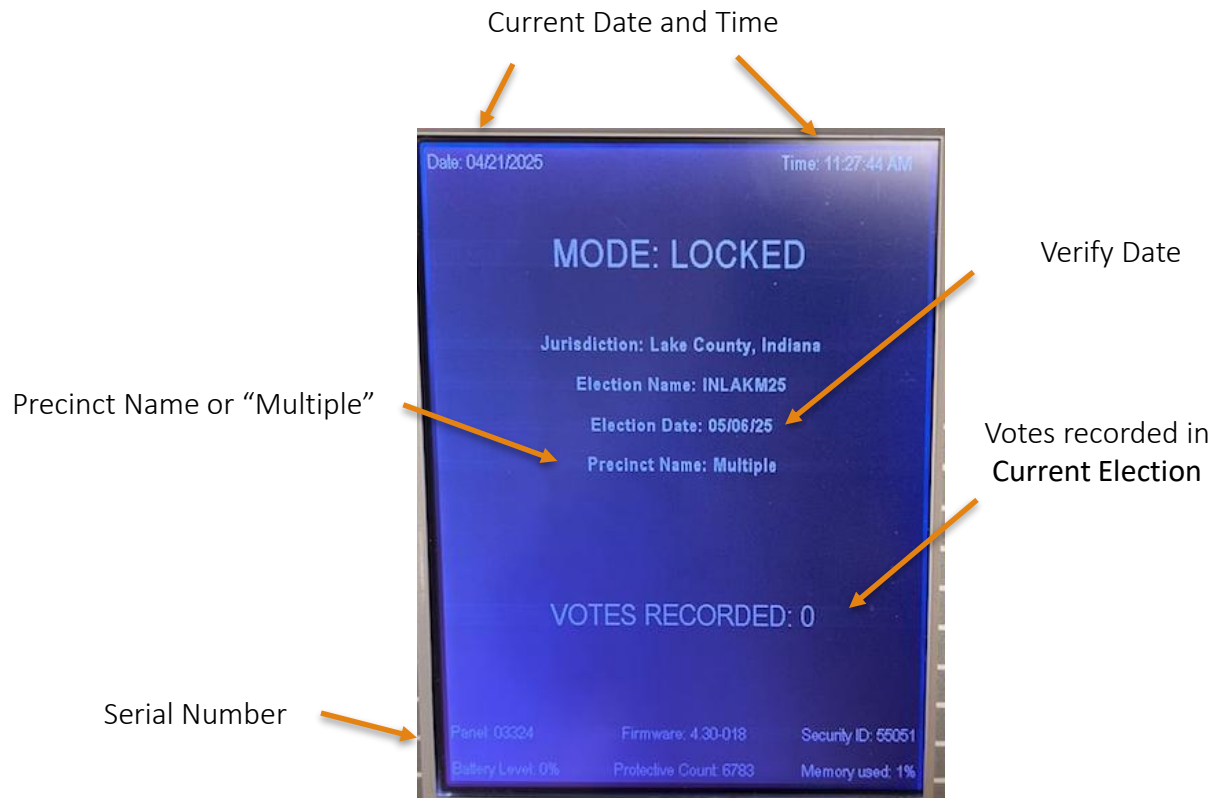

***WHEN THE SCREEN
GOES BLANK***

**LINE UP THE ARROWS, INSERT THE
GREEN START CARD, UNTIL
IT STOPS, AND THE SCREEN WILL COME
ON.**

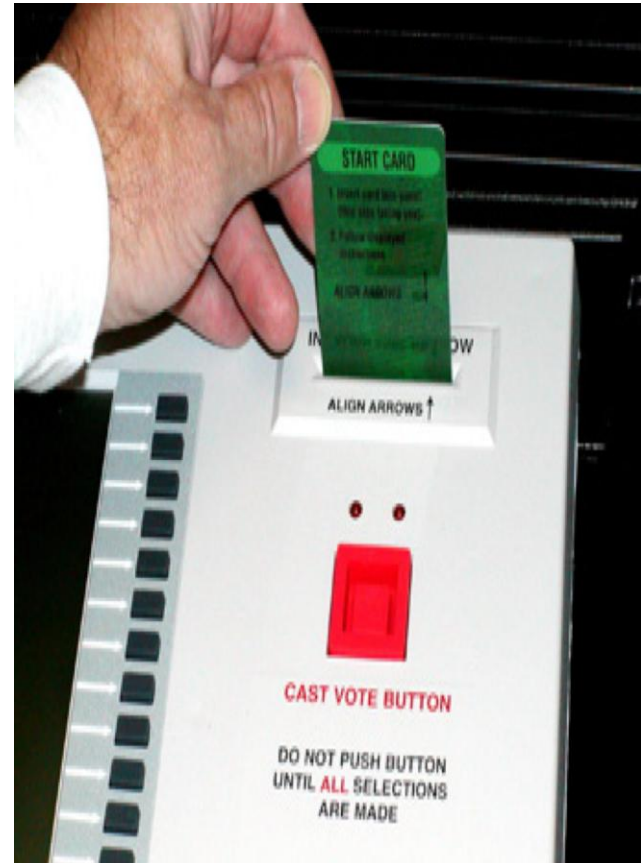

12. Connect the voting machine printer to the port in the booth and Turn the voting machine printer on, be sure the green light is on.
13. Insert Green Start Card and enter password provided (in envelope w/list of the poll workers), then select Done.



14. Select **PRINT ZERO PROOF**, on the voting machine (on Monday simply test the printer. Tuesday is the Official Zero Proof)

15. Verify a header prints on the **VVPAT**, press the button next to Yes, That it printed correctly

16. Select **PRINT**

- * The zero-proof tape will start printing on the voting machine printer

- * Verify the tape has printed & no votes are on the tape.

17. Press the button next to **YES**, that it printed correctly

- * Have the appropriate poll workers sign the zero-proof tape and remove the voting machine printer from the port.

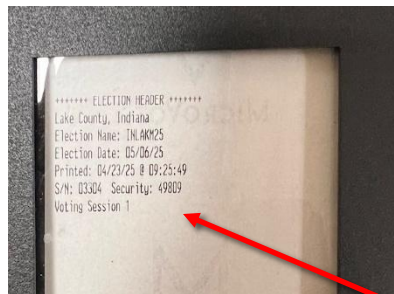

VVPAT HEADER

Show the ballot on the voting machine and compare it to the sample ballot.

18. YOU WILL SEE SEVERAL CHOICES – CHECK BUTTONS, CHECK DISPLAY, SHOW BALLOT, PRINT ZERO PROOF, LIGHTEN DISPLAY, AND DARKEN DISPLAY.
19. PRESS THE SHOW BALLOT BUTTON AND COMPARE THEM TO THE SAMPLE BALLOT IN THE BLACK ROLLER BAG. (Primary Test Both Democrat Ballot & Republican Ballot)
20. WHEN AT THE LAST PAGE OF THE BALLOT, PRESS THE RED CAST VOTE BUTTON TO RETURN TO THE MENU.
21. WHEN THESE STEPS ARE COMPLETED REMOVE THE GREEN CARD AND TURN OFF VOTING MACHINE AND RESEAL THE VOTING MACHINE CASE WITH THE SEALS PROVIDED.

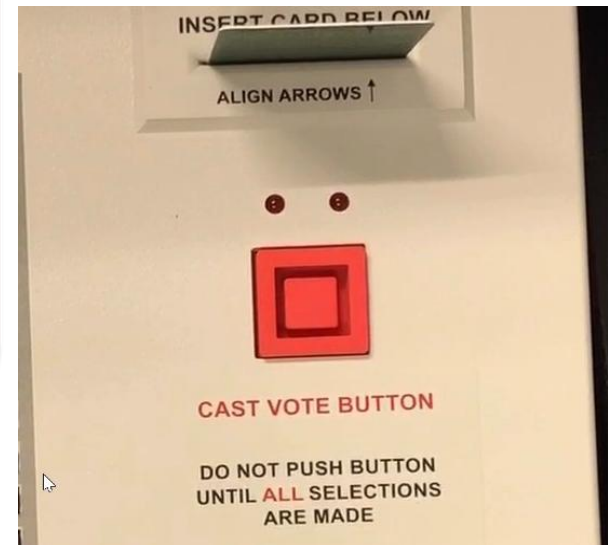
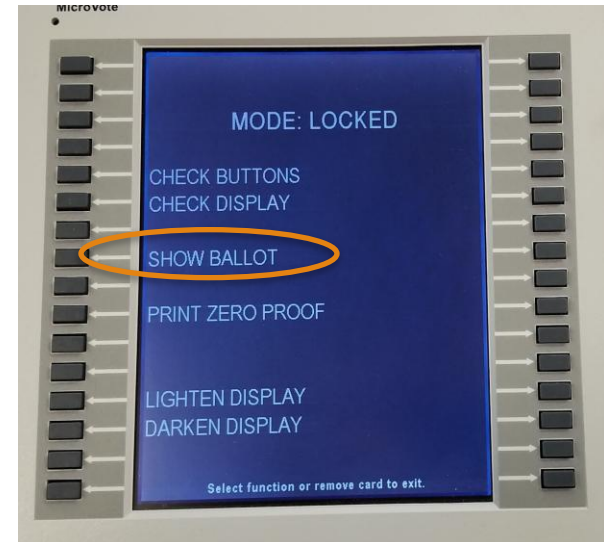

TUESDAY ELECTION MORNING

**Repeat Procedures on
Pages 11 through 15!**

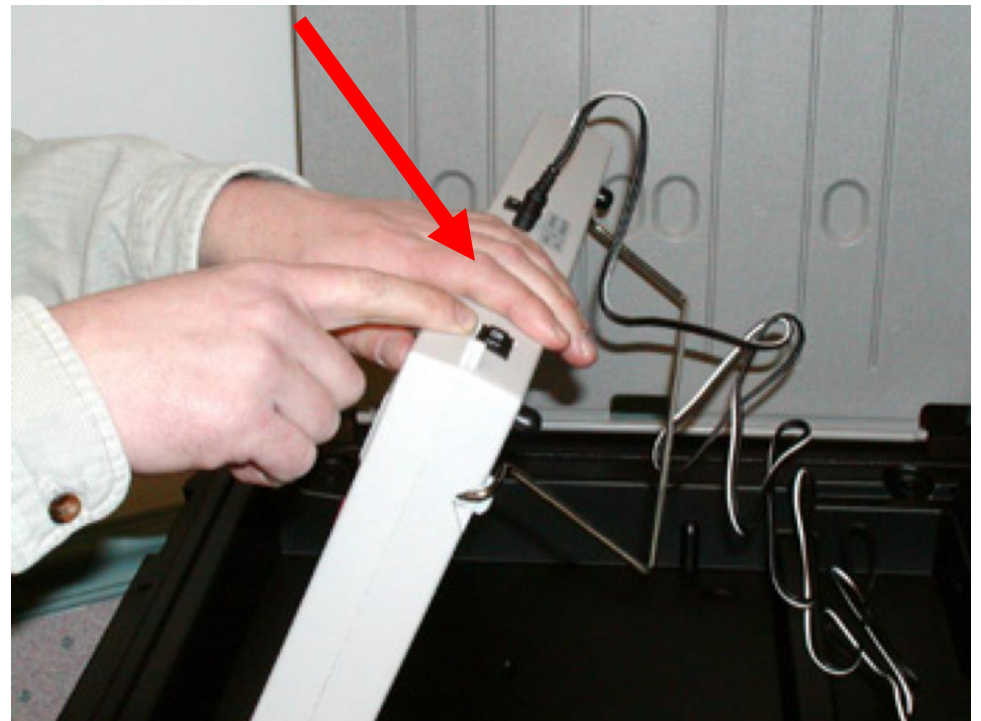

NOW YOU ARE READY TO START THE ELECTION

22. YOU WILL SEE SEVERAL CHOICES – CHECK BUTTONS, CHECK DISPLAY, SHOW BALLOT, PRINT ZERO PROOF, LIGHTEN DISPLAY, AND DARKEN DISPLAY, AND START ELECTION.

23. PRESS SHOW BALLOT AND PROOF IF NOT DONE ON MONDAY. MACHINE WILL NOT START ELECTION UNLESS YOU PRINT A ZERO PROOF TAPE FIRST. YOU WILL BE INSTRUCTED TO PRESS THE BUTTON NEXT TO “START”.

24. WHEN THESE STEPS ARE COMPLETED, REMOVE THE GREEN START CARD AND YOU ARE READY FOR VOTING

25. WITH NO CARD INSERTED, PRESS THE RED CAST VOTE BUTTON.

26 THE SCREEN SHOULD DISPLAY MODE: VOTING ENABLED. THIS ENSURES YOU HAVE SUCCESSFULLY STARTED THE VOTING MACHINE.



REPEAT PREVIOUS STEPS TO START EACH MACHINE. AFTER THE LAST MACHINE IS STARTED, PLACE THE START CARD BACK INTO THE WHITE ENVELOPE.

TUESDAY ELECTION DAY OPENING THE POLLS

1. Arrive at polling location between 5:00 and 5:30 AM. Don't replace any workers until at least 6:10 AM.
2. Open the Inspector's Forms Book.
3. Swear in all Poll Workers if you've not already done so.
4. Check Ballot if not done on Monday, print Zero Proof Tape and place in a white envelope #1 and start Election.
5. Set up Jet Pack/Hot Spot/Cradle Point, Poll Pad Printer and then Poll Pad.
6. Complete step 1-4 in the Inspector Forms Book.
7. Put Up 50 Foot rope with "The Chute Starts Here" sign.
8. If you received ADA Equipment at your polling place, be sure to install.
9. Announce opening of polls at 6:00 AM. *(Step 5)*
10. Write down how many voters were in line when you OPENED/12:30PM/CLOSED. *(FORM # PRE-1(Forms Book, Step 6)*



ALL JUDGES WILL NEED A BLUE VOTE CARD ATTACHED TO A WRIST COIL

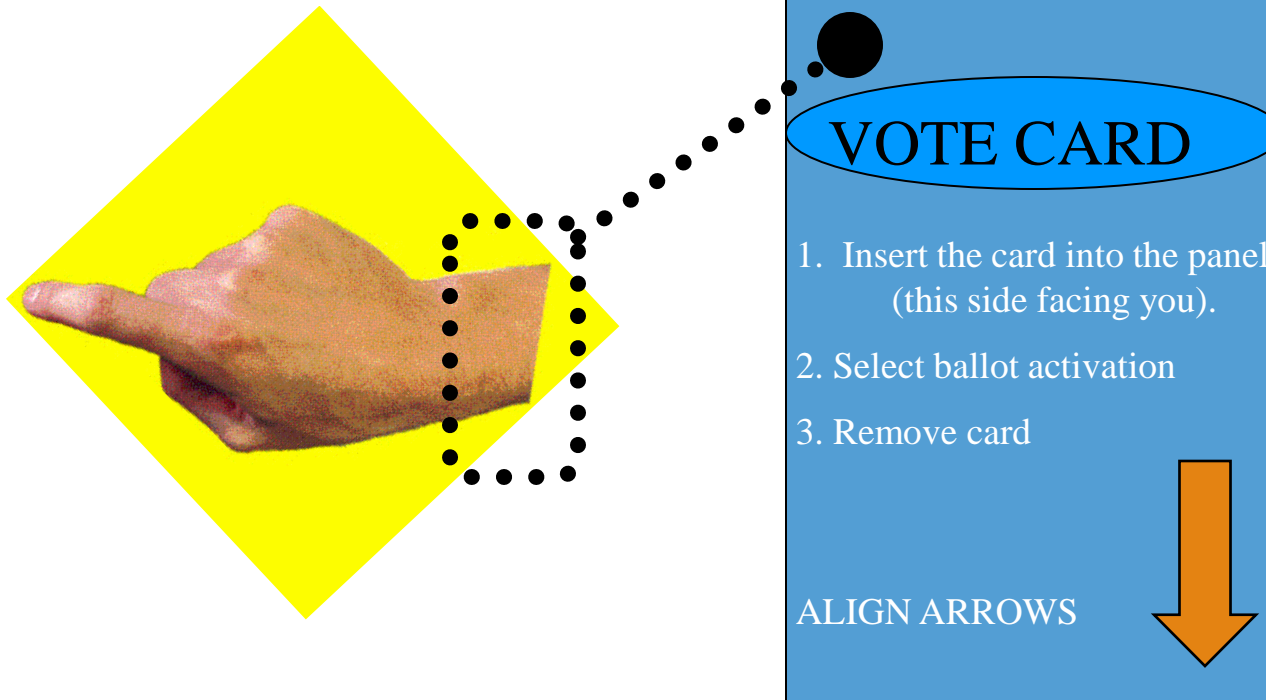

KEEP COIL ON WRIST AT ALL TIMES,

NEVER ALLOW VOTER TO HANDLE THE VOTE CARD

MACHINE OPERATION and BALLOT ACTIVATION

ALIGN ARROWS,
INSERT THE BLUE VOTE CARD INTO THE
VOTING PANEL.

SELECT PARTY AFFILIATION BASED ON
THE POLL PAD RECEIPT

WHEN THE BALLOT APPEARS ON THE
SCREEN, REMOVE THE VOTE CARD.

ALLOW THE VOTER TO ENTER THE
BOOTH.

PLACE THE RECEIPT IN THE ENVELOPE
PROVIDED



**NOTE: PARTY AFFILIATION CAN NOT BE CHANGED
ONCE THE RECEIPT IS PRINTED FROM THE POLL
PAD. NO EXCEPTION.**

CAST VOTE

- ❖ A VOTER MUST MAKE AT LEAST ONE SELECTION AND VIEW ALL PAGES.
- ❖ AFTER THEIR SELECTIONS HAVE BEEN MADE, PRESS THE BUTTON TO CONFIRM VOTE. THE TWO LIGHTS ABOVE THE RED CAST VOTE BUTTON WILL LIGHT UP.
- ❖ THE VVPAT WILL PRINT THEIR SELECTIONS FOR REVIEW IN THE VVPAT WINDOW. THEY MAY GO BACK TO REVIEW THEIR SELECTIONS AND MAKE CHANGES, BUT ONLY ONE TIME.
- ❖ THE VOTER WILL PUSH THE CAST VOTE BUTTON TO RECORD THEIR VOTE.
- ❖ "THANK YOU" WILL BE DISPLAYED ON THE SCREEN. INDICATING THE VOTE HAS BEEN RECORDED.

INTRODUCING THE POLL PAD, POLL PAD PRINTER, AND HOTSPOT/MIFI



Do not un-seal the Poll Pad Envelope until Tuesday Morning. Both Parties must be present.

Turning on the HOTSPOT/JETPACK

1. To turn on the Hotspot/Mifi hold the power button (typically on the top edge of the device) for approximately 5 to 8 seconds until you see the device activate.
2. Reposition the location of the Hotspot/Mifi to maximize your connectivity level. Check the number of signal bars on the home screen to determine signal strength.



Hotspot/Jet Pack

SETTING UP THE VERIZON JETPACK HOTSPOT

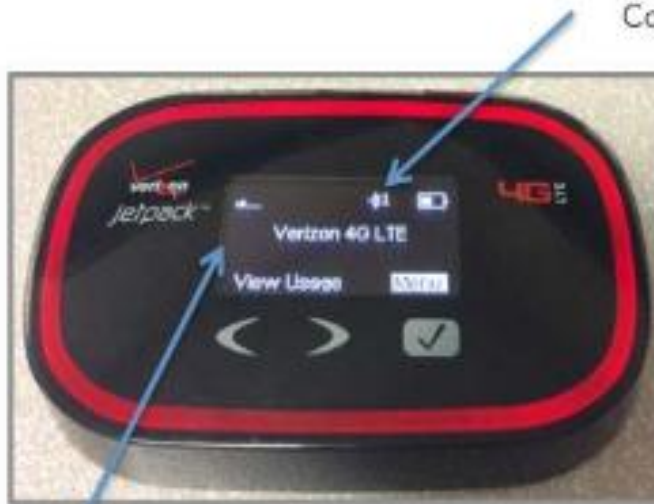

Signal bars

Connected Device Counter

When connected, the Hotspot display will look a lot like a cell phone display. Make sure the hotspot has a good signal. If not, try moving it to a different location in the room, perhaps near a window. The hotspot will work reliably within 80' +/- of the Poll Pads.

Tap the **Power Button** to "wake up" the Hotspot screen if you need to confirm connectivity during the day.

Turning on the Cradle Point

Cradle Point

1. Screw the 2 or more rabbit ears into the Cradle Point and connect it to a power source



**IF YOU ARE HAVING CONNECTIVITY ISSUES WITH YOUR POLL PADS,
CONTACT THE COUNTY OFFICE FOR GUIDANCE**

PRINTER SETUP

1. Position the Printer and Poll Pad on the table.
2. Connect the Printer power cord
3. Connect the AC adapter to the power cord.
4. Connect the AC adapter to the connector on the printer.
5. Insert the power cable plug into an outlet.



Make Sure the Top of the cord (flat part) connected to the poll pad printer is facing up before you insert.

PRINTER SETUP

Election Day Printer Setup

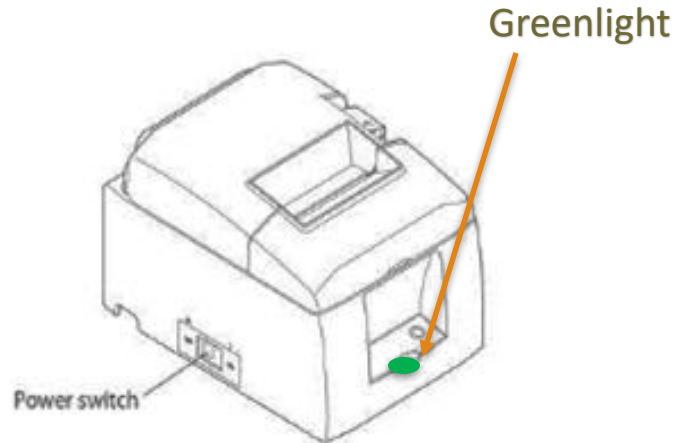

6. Turn Poll Pad Printer ON (switch is on the left side of printer).
The power lamp on the front control panel will light Green and the Poll Pad Printer and Poll Pad will connect to each other.

CHANGING PAPER ON THE PRINTER

The Printer will be distributed with a full roll paper at the start of the day and will process approximately 1,000 voters. The printer is designed for "drop in" paper loading. To change the paper:

Step 1 - Push the cover access lever on the top of the printer backwards in the direction of the arrow and lift the printer top upwards.

Remove and discard the remaining paper & plastic spindle.

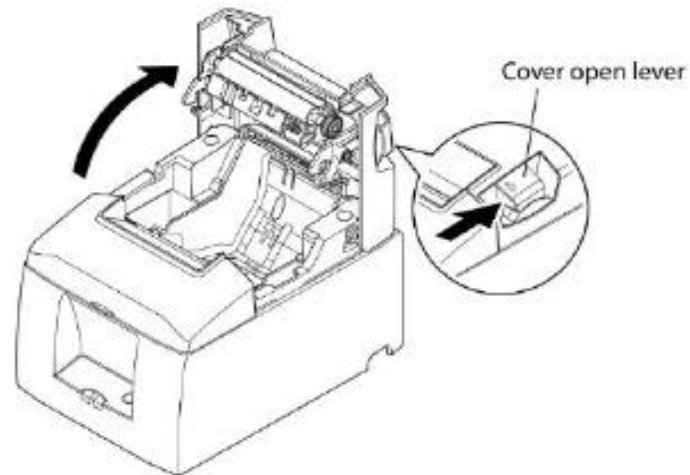

CHANGING PAPER ON THE PRINTER

Step 2 - Release the leading edge of the new paper roll and place in the printer. The paper should feed under the roll and then up towards the top of the printer. Pull the leading edge of the paper towards you and close the cover.

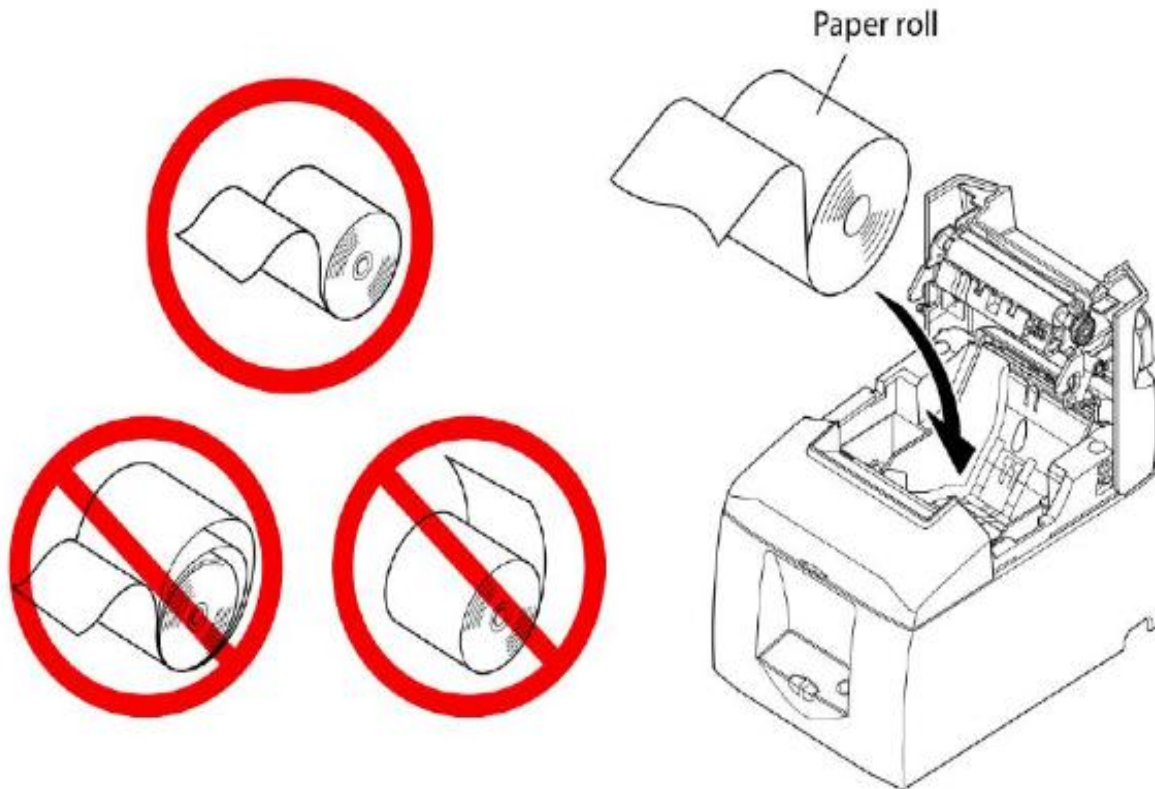

POLL PAD SETUP

UNPACKING THE IPAD



1. IPAD
2. IPAD STAND
3. ID TRAY
4. 2 STYLUS PENS
5. WALL PLUG AND USB CORD

POLL PAD SETUP

1. Turn on the IPAD by pressing the power button located on the upper left side.
2. Click the Poll Pad Icon located at the bottom center of the screen.
3. You will need both a User name and Password for both the Democrat and Republican Poll Workers.

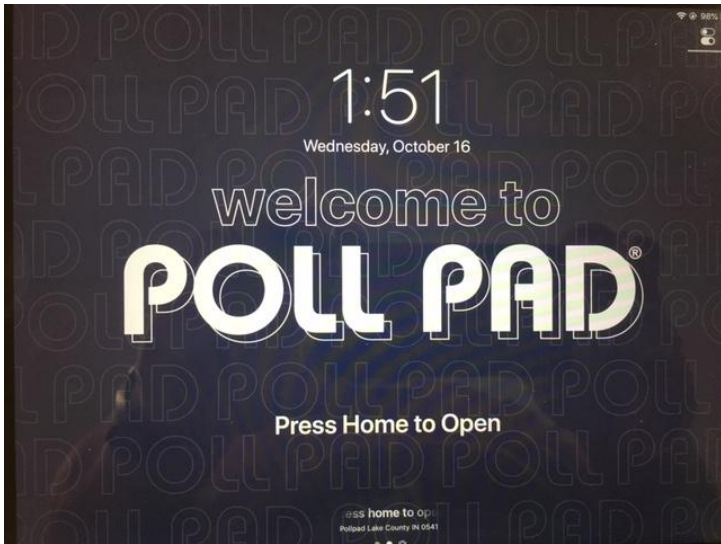

POWER
BUTTON

HOME
BUTTON

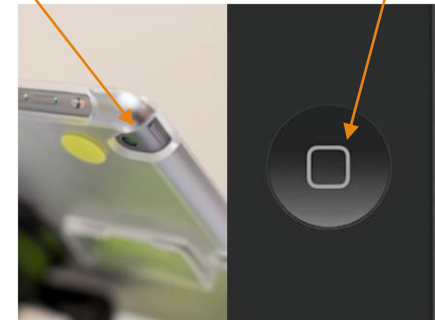

Poll Worker Login:
User Name and Password will be included in the
Kit. It is in the envelope with Poll Worker's names.

POLL PAD SETUP

user name and password

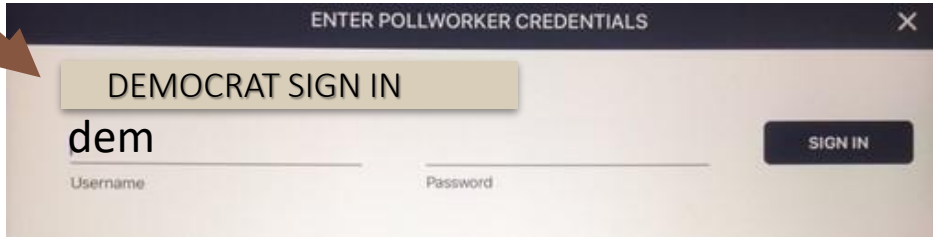
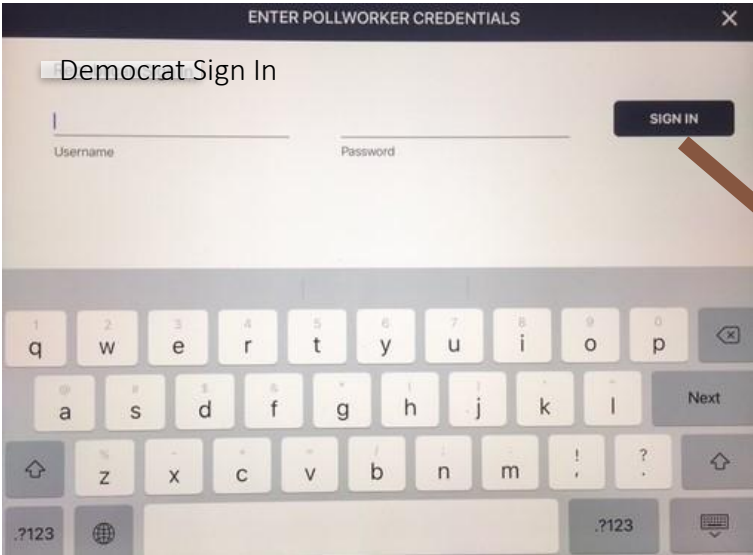
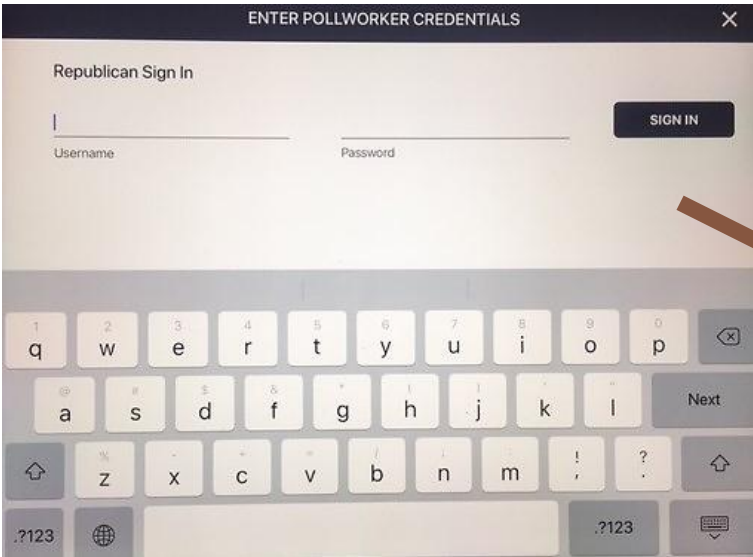

POLL PAD

VERIFY YOUR CHECK-IN COUNT IS AT ZERO, ELECTION DATE, AND LOCATION

Lake County

Precinct Records: 354393 Countywide Records: 354393
Checks: 0 Config. Profile: General - Encoding

Check-ins is at Zero

LAKE COUNTY

PRIMARY ELECTION- *"Election Year"*
"Day of Election"
"Precinct Location"

GET STARTED

POLL PAD

SCANNING THE BARCODE

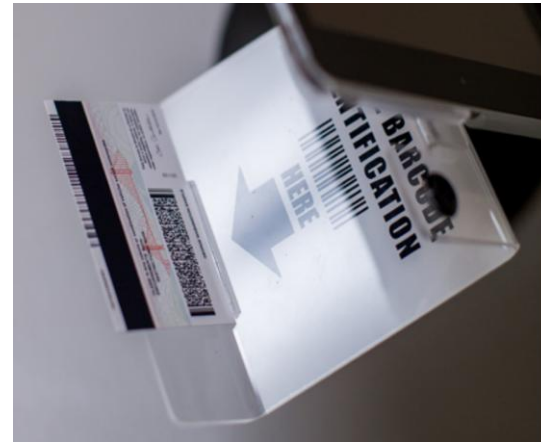
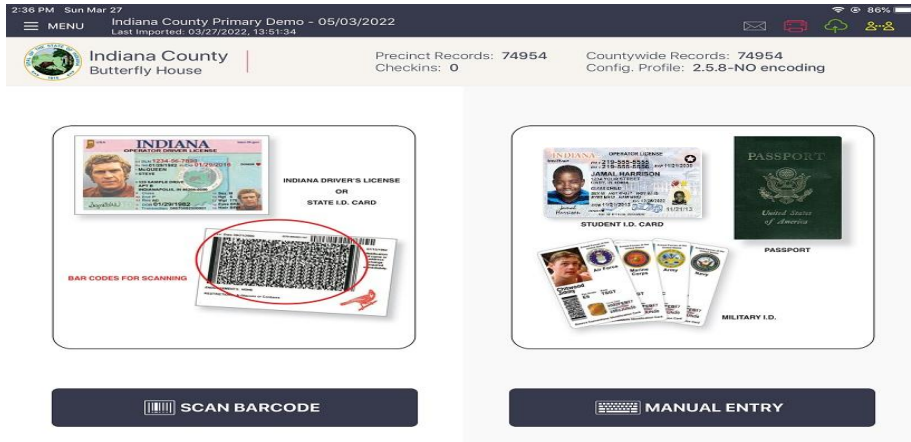

(Actually, look at the ID to ensure it meets the 4 voting criteria)

1. The voter's ID displays the voter's photo.
2. The voter's name on the ID must conform to the name on the voter registration record.
3. With one exception, the voter's ID must contain an expiration date and either still be current or have expired sometime after the date of the most recent General Election 11/5/2024.
 - * Military or veteran IDs with expiration dates meet this requirement
 - * The following IDs need not contain an expiration date, as long as they comply with the other requirements: IDs issued by the U.S. Department of Defense, the U.S. Department of Veterans Affairs (or Veterans Administration), a branch of the uniformed services, the Merchant Marines; or the Indiana National Guard, or a Native American Indian tribe or band recognized by the U.S. Government.
4. The voter's ID must be issued by the State of Indiana or the U.S. government

POLL PAD

SCANNING THE BARCODE

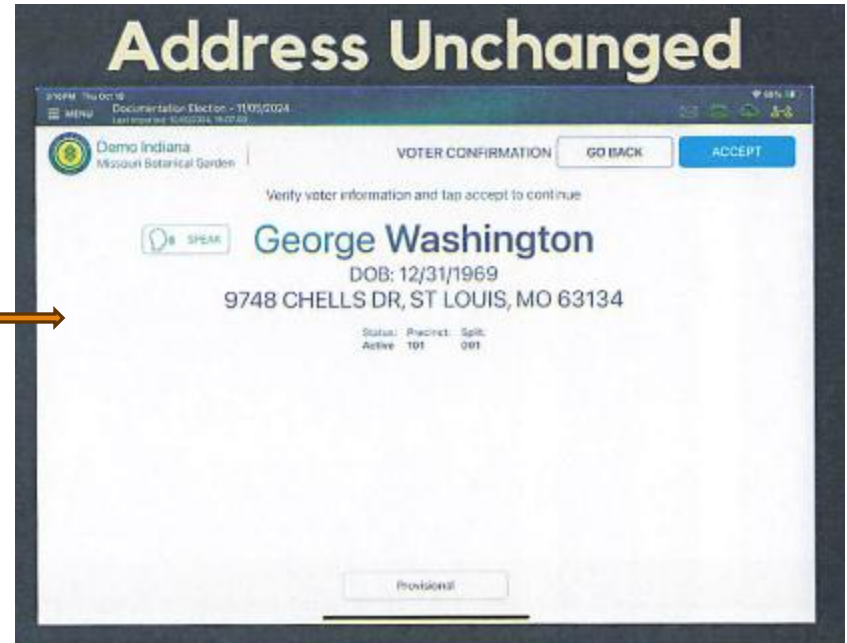
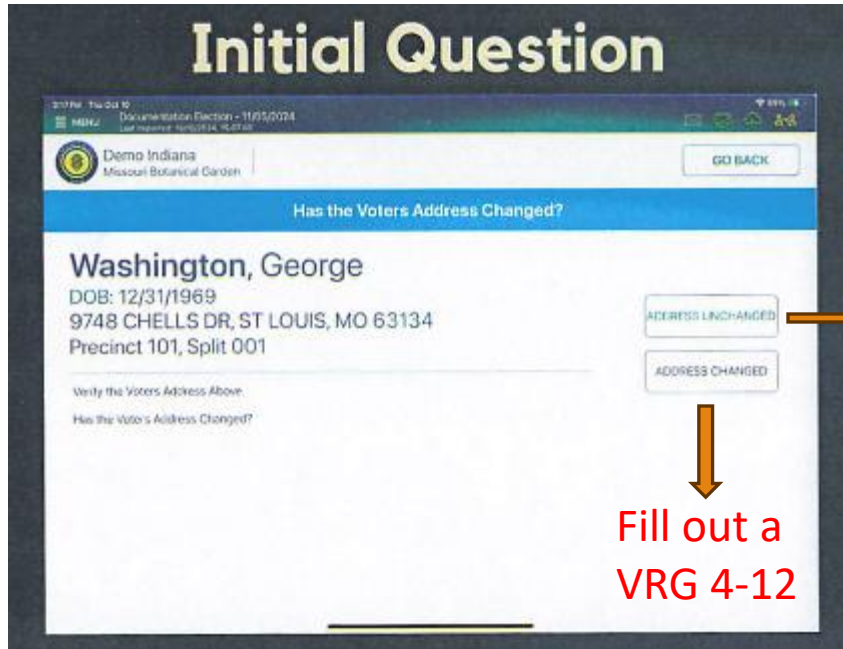

Voter Must Select party affiliation

1. For Primary Elections, Turn the Poll-Pad to the Voter and allow the Voter to select their Party Affiliation by **tapping the button only one time**. The voter will then select “Accept.”



Indiana County
Butterfly House

PARTY SELECTION

GO BACK

ACCEPT

Choose your party and tap Accept button to continue.

Democratic

Republican

Voter will select their party affiliation!

AFFIRMATION OF RESIDENCY

Displays as a flag on the voter's record called "Affirmation of Residency Required"

Displays after Voter Address Affirmation(V.A.A.) workflow and Proof of Residency for Proof of Residency voters

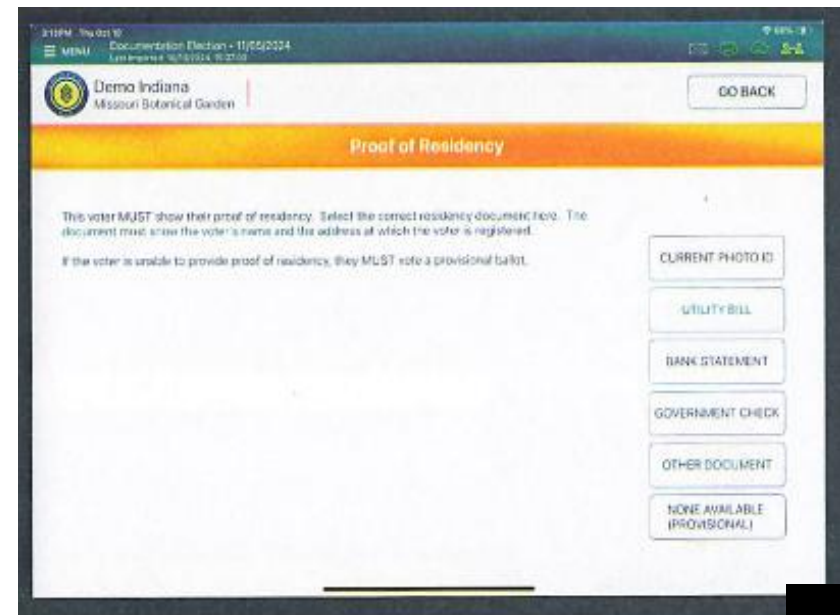
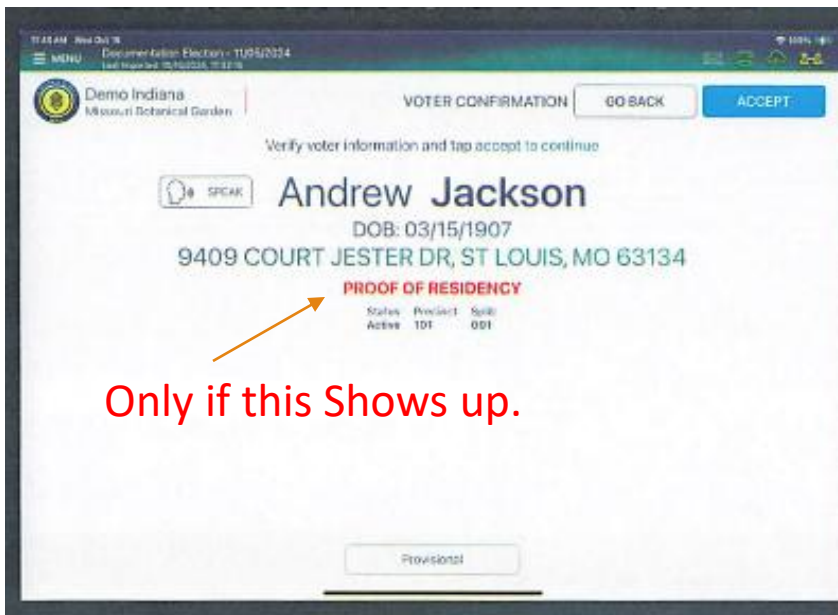

PROOF OF RESIDENCY

Used for voters who are marked to provide additional proof of residence before voting

- Voter must provide proof from prescribed list
- Only required for voters marked with this status
- If no proof is available, voter may vote provisionally

2:08 PM The City of Documentation Election - 11/05/2024
Last Modified: 11/05/2024, 11:07:30

Demo Indiana
Missouri Botanical Garden

Proof of Residency

This voter **MUST** show their proof of residency. Select the correct residency document here. The document must show the voter's name and the address at which the voter is registered.
If the voter is unable to provide proof of residency, they **MUST** vote a provisional ballot.

GO BACK

CURRENT PHOTO ID
UTILITY BILL
BANK STATEMENT
GOVERNMENT CHECK
OTHER DOCUMENT
NONE AVAILABLE (PROVISIONAL)

2:10 PM The City of Documentation Election - 11/05/2024
Last Modified: 11/05/2024, 11:07:30

Demo Indiana
Missouri Botanical Garden

Proof of Residency

This voter **MUST** show their proof of residency. Select the correct residency document here. The document must show the voter's name and the address at which the voter is registered.
If the voter is unable to provide proof of residency, they **MUST** vote a provisional ballot.

GO BACK

WYCHECK
GOVERNMENT DOCUMENT
DRIVER'S LICENSE
OTHER DOCUMENT
NONE AVAILABLE (PROVISIONAL)

Proof of Residency Additional Documentation

Who is required to show additional documentation, beyond a photo ID?

1. This requirement applies to voters who registered to vote by mail for the first time in Indiana.
2. If a voter is required to show additional documentation, this will be noted in the poll book.

Examples of Acceptable Documents

- * Indiana Driver's License or ID card with current address=DL
- * Current Utility Bill=UB
- * Bank Statement=BK
- * Government Check=GV
- * Paycheck=PY
- * Government Document=GD
- * Current and Valid Photo ID =PH

IF THE VOTER HAS NO DOCUMENTATION AND/OR SIGNS THE POLL PAD, THE VOTER MUST VOTE PROVISIONAL BALLOT.

1. The voter will then sign the Poll Pad and affirm his or her selection to the prior page is correct. The voter will then select “Done Signing”

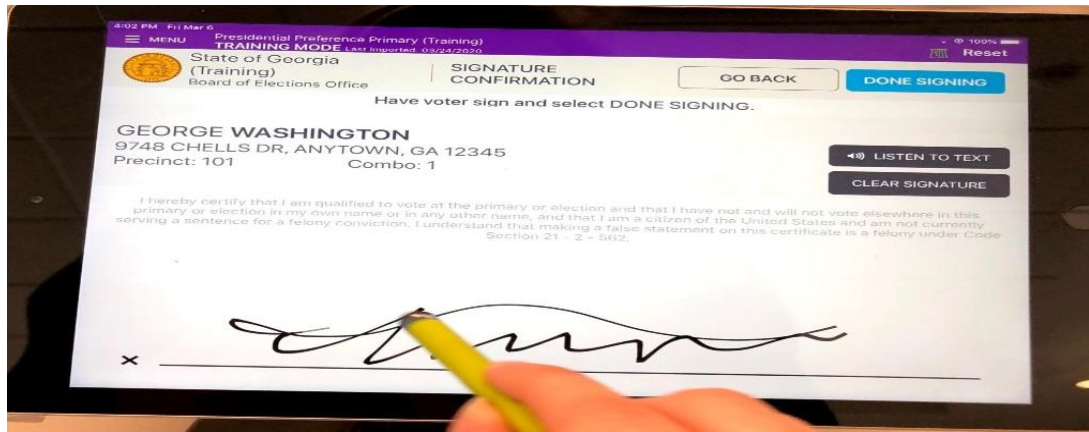

2. Turn the Poll Pad back towards you (the Clerk) and compare the voter signature from the Poll Pad with the one on file then select “Submit” to complete the processing of the voter.

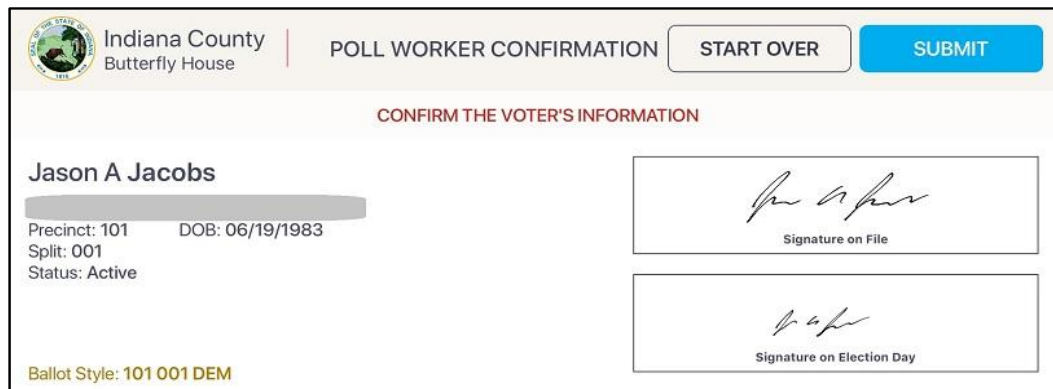

3. You will receive confirmation that the voter has been processed and the voter slip will be generated from the Poll Pad Printer. Give this slip to the Poll Judge, who will accompany the voter to the voting booth.



POLL PAD

MANUAL SEARCH

For voters with a passport or military ID (or the license does not scan, you can perform a Manual Search by selecting that button from the Main Screen.

You may enter a few letters of the voter's last name, then a few letters of the first name, then press "Search" to bring up all matching options. You can then scroll the screen upwards to find the voter match. Tap on the voter's name to advance to the Address Confirmation Screen.

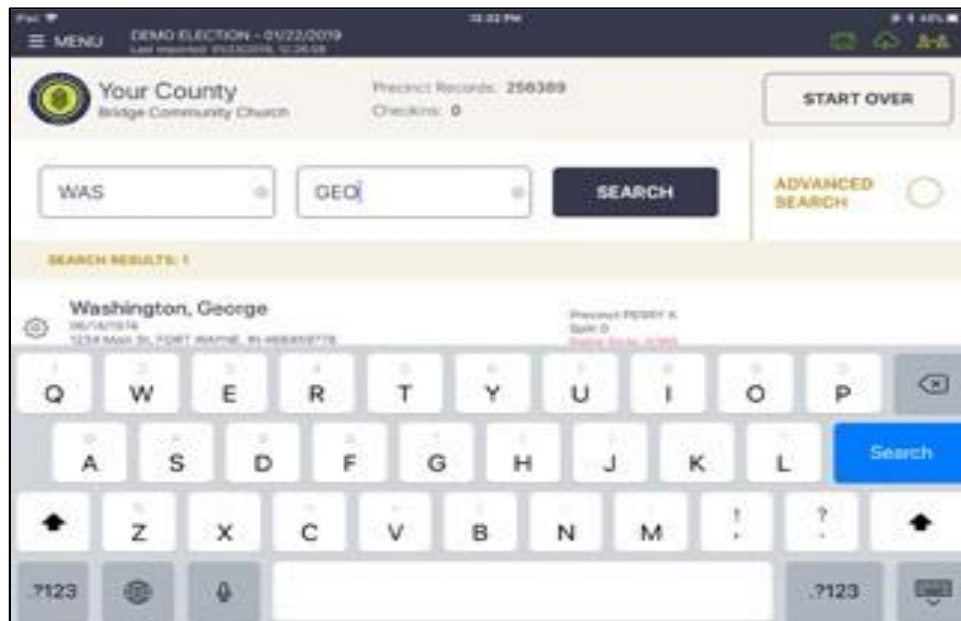

MANUAL SEARCH

On the Manual search screen, you may also select “Advance Options” and choose to enter other information, such as DOB, ADDRESS, AND LICENSE NO. to further narrow down the options to find the correct voter. When a voter is found, please follow the pages 38 to 43.

The screenshot shows the Clay County Manual Search interface. At the top left is the Clay County logo. To its right, the text reads "Clay County", "Clay Community Schools", and "Central Office". Further right, it displays "Precinct Records: 18631" and "Checkins: 0". A "START OVER" button is located in the top right corner. Below this header is a search section with two input fields: "Last Name" and "First Name". To the right of these fields are two buttons: "Search" and "ADVANCED OPTIONS". Below the search fields is a table with the following headers: "DOB", "ADDRESS", "LICENSE NO.", "VOTER ID", "PRECINCT CODE", "STATUS", and "RESET". The "DOB" header is underlined. Below the headers, the table contains a row with the following values: "00 / 00 / 0000". Below these values are the labels "MONTH", "DAY", and "YEAR". A "CLEAR" button is located to the right of the "0000" value. A close button (X) is located in the top right corner of the table area.

If you cannot locate a voter on the Poll Pad, contact your county office at 219-755-3795 for guidance.

THESE IDs ARE NOT VALID FOR VOTING PURPOSES IN INDIANA



These IDs ARE NOT VALID for voting purposes in Indiana.

A photo ID must meet 4 criteria to be acceptable for voting purposes.

It must:

1. Display the voter's photo
2. Display the voter's name, and the name must conform to the voter registration record
3. Display an expiration date and either be current or have expired sometime after the last General Election 11/5/2024
4. be issued by the State of Indiana or the U.S. government



Photo ID Law

What are the requirements under the Photo ID Law?

1. Voter's photo must be displayed on the ID
2. Voter's name on the ID must conform to the name on the poll book
3. Expiration date (current or expired after the date of the last General Election; expiration dates of INDEF also work) **11/5/2024**
4. Issued by the State of Indiana or the US government

Poll worker should NOT be checking for address

Photo ID "Conform" Example

- ✓ The voter's name on the Photo ID must conform to the name on the voter registration record
- ✓ People commonly use nicknames, middle names, and initials as a substitute for their given first name
 - Robert John Crew
 - Robert J. Crew
 - Robert Crew
 - R. John Crew
 - R. J. Crew
 - Bob John Crew
 - Bob J. Crew
 - Bob Crew
 - John Crew
 - J. Crew

Conform does NOT mean it needs to match identically

THE HELP AMERICA VOTE ACT

Is a Federal Law requiring each polling place to be accessible to elderly voters and voters with disabilities.

- 1. Polling places should have accessible parking and obstructions to entrances should be removed.**
- 2. Poll workers should never assume a voter wants assistance.**
- 3. Be aware that dogs assisting people with disabilities must be admitted into the polling place.**

PEOPLE WITH DISABILITIES CAN BRING SOMEONE TO THE POLLS TO ASSIST THEM IN THE VOTING BOOTH, OR THEY MAY REQUEST BIPARTISAN JUDGES TO ASSIST THEM. THE JUDGE MUST FILL OUT A FORM PRE-3 IN THE INSPECTOR BOOK AND BOTH JUDGES MUST SIGN.



AFFIDAVITS OF VOTER ASSISTANCE

State Form 28192 (R10 / 5-19)
Indiana Election Division (IC 3-11-9-2, 3-11-9-3)

(PRE-3)

INSTRUCTIONS: Complete PART A or PART B – NOT BOTH. Return completed form in PRE-15 envelope.

PART A		AFFIDAVIT OF PERSON DESIGNATED TO ASSIST A VOTER	
A	INSTRUCTIONS:		
A	1. This affidavit must be completed BEFORE the voter enters the voting booth at the polls or to cast an absentee ballot.		
A	2. The person who has been designated by a voter to assist the voter in the voting booth because of a disability (or the voter's inability to read or write English) must sign the affidavit.		
A	3. The voter may designate a person of voter's choice, other than the voter's employer, an officer of the voter's union, or an agent of the voter's employer or union.		
A	4. The precinct election board or absentee voter board will keep this affidavit and return it with the other election supplies at the end of the day.		
A	State of Indiana, <u>Lake</u> County:		
A	I, the undersigned, affirm that to the best of my knowledge, the voter, _____, whom I assist in voting:		
A	1. Is a voter with a disability as defined in IC 3-5-2-50.2 (or is unable to read or write English); and		
A	2. Has requested my assistance in voting at this election.		
A	This must be subscribed and sworn to before person authorized to administer oaths, such as the precinct inspector or absentee board member.		
A	Signature of Person Assisting Voter	Printed Name of Person Assisting Voter	
A	<u>Poll worker sign</u>		<u>Date</u>
A	Subscribed and sworn to before me, this _____ day of _____, 20_____.		
A	Signature of Person Administering Oath	Title	
A	<u>Poll worker sign</u>	<u>Position</u>	
PART A		IF THIS SECTION HAS BEEN FILLED OUT, DO NOT FILL OUT PART B.	
PART B		AFFIDAVIT OF THE TWO JUDGES OR ABSENTEE BOARD MEMBERS ASSISTING A VOTER	
B	INSTRUCTIONS:		
B	1. This affidavit must be completed and signed by the two (2) election judges BEFORE the voter enters the voting booth at the polls OR by the two (2) absentee board members BEFORE the voter is given an absentee ballot.		
B	2. The judges or absentee board members may assist any voter in marking the voter's ballot if the voter does not wish to designate a person of the voter's choice to assist the voter.		
B	3. Only those voters who require assistance because of a disability (or the voter's inability to read or write English) may be assisted by the judges in the voting booth OR by the absentee board members.		
B	4. The precinct election board will keep this affidavit and return it with the other election supplies at the end of the day OR the county election board will keep this affidavit.		
B	State of Indiana, <u>Lake</u> County:		
B	I, the undersigned, affirm that to the best of my knowledge, the voter, _____, whom I assist in voting:		
B	1. Is a voter with a disability as defined in IC 3-5-2-50.2 (or is unable to read or write English);		
B	2. Has requested my assistance in voting at this election; and		
B	3. Does not wish to designate a person to assist the voter in voting under IC 3-11-9-2.		
B	This must be subscribed and sworn to before person authorized to administer oaths, such as the precinct inspector or absentee board member.		
B	Signature of Judge or Absentee Board Member	Printed Name of Judge or Absentee Board Member	
B	<u>Signature of Judge</u>	<u>Printed Name</u>	
B	Signature of Judge or Absentee Board Member	Printed Name of Judge or Absentee Board Member	
B	<u>" "</u>	<u>" "</u>	
B	Subscribed and sworn to before me, this _____ day of _____, 20_____.		
B	Signature of Person Administering Oath	Title	
B	<u>Signature of Inspector</u>	<u>Position</u>	
PART B		IF THIS SECTION HAS BEEN FILLED OUT, DO NOT FILL OUT PART A.	

Precinct Poll Inspectors

THE INSPECTOR MANAGES THE POLLING PLACE

1. THE INSPECTOR SHALL ASK VOTERS TO PROVIDE PHOTO ID.
2. CHALLENGE VOTERS AND ACCEPT CHALLENGES.
3. THE INSPECTOR PICKS UP ELECTION SUPPLIES ON THE SATURDAY PRIOR TO ELECTION.
4. THE *POLL WORKER WILL GIVE THE OATH TO THE INSPECTOR, THEN THE INSPECTOR WILL ADMINISTER THE OATH TO ALL POLL WORKERS (PRE-1, PRECINCT OATH BOOK). (STEPS 1 & 2 IN INSPECTOR FORM BOOK).*
5. THE INSPECTOR ANNOUNCES THE OPENING AND CLOSING OF THE POLLING PLACE. *(STEPS 5 IN INSPECTOR FORM BOOK)*
6. ACCOMPANIED BY THE JUDGE OF THE OPPOSITE POLITICAL PARTY, THE INSPECTOR RETURNS ALL ELECTION SUPPLIES AT THE DROP OFF SITE.
7. THE INSPECTOR MAKES SURE THE CERTIFICATE OF EXPENSE IS FILLED OUT AND SIGNED BY THE POLL WORKERS.

NO ONE IS ALLOWED IN THE POLLING PLACE WITHOUT CREDENTIALS



For more information, see Election Day Handbook page 1-5

WHO IS ALLOWED IN THE POLLING PLACE?

Voters casting ballots (and children under 18 with the voter).
Individuals with authorized credentials. Precinct election officials (inspectors, judges, poll clerks). An individual authorized to assist a voter in voting (can not be a union rep, or the voter's employer, or people without proper credentials).

If the voter requests assistance, but does not designate someone to help them, both Judges must accompany the voter into the voting booth and assist the voter.

A person assisting a voter (including Judges), must complete the Affidavit of Voter Assistance (PRE-3), before entering the voting booth.

WHO IS ALLOWED IN THE POLLING PLACE WITH CREDENTIALS

STATE OF INDIANA }
COUNTY OF LAKE } ss: **Board of Election Commissioners**

Date 5/5/2026

..... is hereby appointed to serve as

Deputy Election Commissioner	Special Messenger
Voting Machine Mechanic	Courier / Counter
Member Absent Voter Traveling Board	Election Board Member

and is to be admitted to any polling place for the **Primary Election** Election.

.....
.....
.....
Michael G. Brown

I, do solemnly swear that I will support the Constitution of the United States of America and the Constitution of the State of Indiana, and that I will faithfully, honestly and impartially discharge my duties in connection with the Elections, to the best of my skill and ability, So Help Me God.

.....
Subscribed and sworn to before me this.....day of..... 20.....
.....
Notary



POLLWORKER PAY SCALE

2026 POLLWORKER PAY SCALE				
POSITION	BASE PAY	TRAINING	Republican Judge Assist Inspector to Drop-Site	TOTAL
INSPECTOR	210	30		240
REP JUDGE	145	30	25	200
CLERKS	145	30		175

IF THE REPUBLICAN JUDGES IS REQUIRED TO RETURN THE ELECTION SUPPLIES WITH THE INSPECTOR AND SIGN THE RETURN SHEET, THEY WILL RECEIVE AN ADDITIONAL \$25 IN PAY. IC 3-6-6-28 & IC 3-12-2-7

STATEMENT OF EXPENSE

LS 01

Township or Ward _____ Precinct _____
STATEMENT OF EXPENSE OF ELECTION BOARD AND OFFICERS PRIMARY ELECTION, MAY 4, 2010

- NOTE: PLEASE PRINT**
1. Each board member and officer must fully complete the appropriate portions of this form.
 2. PLEASE PRINT all information requested. Inspector: include name and address of polling place.
 3. Federal Law requires that we report election workers compensation each calendar year.
 4. File this statement with the Auditor in care of the Lake County Election Board at the same time the election returns are made.

	TRAINING	BASE AMOUNT	TOTAL	WARRANT NUMBER
INS. REP. Name X _____ Soc. Sec.# _____ - - - - - Phone _____ Address _____ Zip Code _____		\$150.00*		
Name X _____ Soc. Sec.# _____ - - - - - Phone _____ Address _____ Zip Code _____		\$100.00*		
REP. JUDGE Name X _____ Soc. Sec.# _____ - - - - - Phone _____ Address _____ Zip Code _____		\$100.00*		
DEM. CLERK Name X _____ Soc. Sec.# _____ - - - - - Phone _____ Address _____ Zip Code _____		\$100.00*		
Name X _____ Soc. Sec.# _____ - - - - - Phone _____ Address _____ Zip Code _____				
Name X _____ Soc. Sec.# _____ - - - - - Phone _____ Address _____ Zip Code _____				
Name X _____ Soc. Sec.# _____ - - - - - Phone _____ Address _____ Zip Code _____				
Total		\$500.00*		

PLEASE CHECK HERE IF YOU ATTENDED A TRAINING SESSION. This will be Verified.

PLEASE PRINT ALL INFO CLEARLY INCLUDING CITY AND ZIP CODE

POLLING PLACE INFORMATION

I, the undersigned, hereby certify that the Election Board organized at 10:00 a.m., May 4, 2010 and continued in session until 6:00 o'clock p.m., May 4, 2010.

INSPECTOR
 DEMOCRAT CLERK
 REPUBLICAN CLERK
 REPUBLICAN JUDGE
→ All Members of the Board MUST Sign above or Checks will not be issued.

Pursuant to the provisions and penalties of IC 5-11-10-2, I certify that the foregoing account is true and correct; that claimed is legally due, after allowing all just credits; the amount of the same has been ascertained.

INSPECTORS SIGN HERE ALSO

APPROVED BY THE STATE BOARD OF ACCOUNTS FOR LAKE COUNTY 2009. Date _____

CHECKS WILL BE
MAILED 5 weeks after
an Election.

990012100 41196 Salaries \$ _____

990012100 43796 Rent \$ _____

Vendor No. _____

IN FAVOR OF

(Print) Inspector's Name _____

Address _____

City State Zip _____

Pct. No. _____

On Account of Primary Election May 3, 2011

Allowed..... 2011

In the sum of \$ _____

SAMPLE

Board of County Commissioners

Warrant No. _____ Issued in payment

Filed 2011

Auditor

10494

I have examined this claim and certify as follows:

That it is in proper form,

That it is duly authenticated as required by law.

That it is based upon contract
statutory authority

That it is apparently correct
incorrect

County Auditor

STATEMENT OF EXPENSE

IF YOU DO NOT CORRECTLY FILL IN THE STATEMENT OF EXPENSE SHEET YOU WILL DELAY PAYMENT FOR ALL YOUR WORKERS.

DO NOT RELY ON THE INSPECTOR TO FILL OUT YOUR PAY INFORMATION. IT IS YOUR RESPONSIBILITY!

REMEMBER YOUR CHECKS ARE MAILED TO THE ADDRESS ON THE CLAIM.

FULL SS# REQUIRED NOT JUST LAST 4.

Audit your numbers

THIS IS MANDATORY

Use the PRE 16 form to audit your precinct.

Note: discrepancies throughout the day, all discrepancies should be noted on the PRE-16 (*Inspector's Form Book*).

Check the number of check-ins on the Poll pad, then ask the judge how many people have voted on the machines. Add the machine numbers together to see if they match the Poll Pad check-ins.

Write it down on the PRE-16 form. If they don't match, you'll need to find out why. Maybe you had someone leave without voting or someone voted Provisional? If so, please write why the numbers didn't match.

Pre-16 part 1



INSPECTOR AND JUDGE'S REPORT OF TOTAL NUMBER OF VOTES CAST ON ELECTRONIC VOTING SYSTEMS IN PRECINCT / VOTE CENTER AND NUMBER OF VOTERS WHO RECEIVED BALLOT AT PRECINCT / VOTE CENTER AS INDICATED BY SIGNING POLL LIST OR EPOLLBOOK

(PRE-16)

State Form 50529 (R2 / 5-23)
Indiana Election Division (IC 3-12-3.5-5(d))

INSTRUCTIONS: This form is used in a precinct / vote center that uses an electronic voting system. After the polls close, each electronic voting system in a precinct / vote center has been secured, and the paper vote total printouts have been obtained, the inspector and the judge of the opposite party shall record the number of votes cast on all electronic voting systems located within the precinct / vote center. Use the work sheet on the reverse side of this form.

The inspector and judge shall also record the number of voters who have received a regular ballot by signing in at the polls, according to the paper poll list or ePollbook for the precinct / vote center and shall determine if there is a difference between the two numbers. Voters receiving a provisional ballot should not be included in this total.

If there is a difference between the total number of votes cast on the electronic voting system and the number of individuals who signed the poll list, then the inspector and judge shall use this form to report the discrepancy to the county election board, including any reasons for the discrepancy, if known. The inspector and judge shall return this form to the county election board with the certificates stating the total number of votes that each candidate received for each office and the votes on each public question.

REPORT OF DISCREPANCY BETWEEN THE NUMBER OF VOTES CAST IN THE PRECINCT / VOTE CENTER AND THE NUMBER OF VOTERS WHO RECEIVED A BALLOT FOR THIS PRECINCT / VOTE CENTER, ACCORDING TO THE POLL LIST OR EPOLLBOOK

Precinct, if applicable: _____ Name of Polling Location or Vote Center: _____

To the lake County Election Board:

We, the undersigned, report the following as required by Indiana Code 3-12-3.5-8:

- 1) We are the duly appointed and acting inspector or judge [or judges] of the opposite political party from the inspector, or are designated under the county voter center plan to perform the duties of the inspector or judge of the precinct polling location or vote center named above.
- 2) Based on the vote total printouts for each electronic voting system used in the precinct / vote center, the total number of votes cast on all electronic voting systems is 89.
- 3) Based on the poll list OR electronic poll book (ePollbook) for this precinct / vote center, the number of voters who received a regular ballot for this precinct / vote center is 88. *Do not include provisional ballot voters in this total.*
- 4) The discrepancy between the number in (2) and the number in (3) is 1.
- 5) The reasons for this discrepancy, if known, are set forth on the reverse of this form.

SIGNED, THIS THE _____ DAY OF Date, 20 _____:

Signature of Inspector

Printed Name of Inspector

Signature of Judge of Opposite Party

Printed Name of Judge of Opposite Party

If additional Judges of the Opposite Political Party are completing this report, insert the printed names and signature of those individuals below:

Signature of Judge of Opposite Party

Printed Name of Judge of Opposite Party

Signature of Judge of Opposite Party

Printed Name of Judge of Opposite Party

VOTING
MACHINE

POLL PAD

REMEMBER
SIGNATURES

Pre-16 part 2

	Votes Cast on Electronic Voting System		Electronic or Paper Poll Lists – Voters Receiving Ballots*	
	Machine Number	Number of Voters	Precinct Name or ePB Number	Number of Voters
1.	1234	37	578	40
2.	2179	52	579	48
3.				
4.				
5.				
6.				
7.				
8.				
9.				
10.				
11.				
12.				
13.				
14.				
15.				
Total				

Machine Number may be the precinct assigned to the voting system, may be an asset tag used by the county, or another tracking method. If using a paper poll list, the name may be the name of the precinct. If using an ePollbook, the name may be the precinct, asset tag number, or another tracking method used by the county. Please contact your county election board for more instruction.

**Do not include provisional ballot voters who signed the poll list in this number!*

DISCREPANCIES OR PROBLEMS

Please describe in detail any discrepancies or problems, such as the use emergency ballots, voting system and others specifying the voter's' individual precinct.

DOCUMENT THESE DISCREPANCIES OR PROBLEMS AS THEY OCCUR BELOW.

VOTER LEFT WITHOUT VOTING - EMERGENCY

VOTER NAME – GEORGE WASHINGTON

This form is mandatory.

THE ONE THAT GOT AWAY

When a voter leaves the booth without “casting” their ballot, The Poll Workers must attempt to alert the Voter. If unable to do so, or the voter declines to return, the Inspector and BOTH Judges must complete the process by pressing the “CAST VOTE” button.

There is a new form in your Inspector booklet (**PRE-9**) that must be signed to document this occurrence by the Inspector and Judges.



THE ONE that HAD TO WAIT

LONG LINES

There's another new form where the Inspector needs to write down how many voters were in line at: 6:00 a.m., 12:30 p.m., and 6:00 p.m.

It is Step 6, and it will be found in your Inspector Booklet.
Make sure you fill it out!!

(PRE-1, INSPECTOR OATH BOOK), STEP 6

This is only the number of people who ARE in line at that time and NOT the total votes processed.

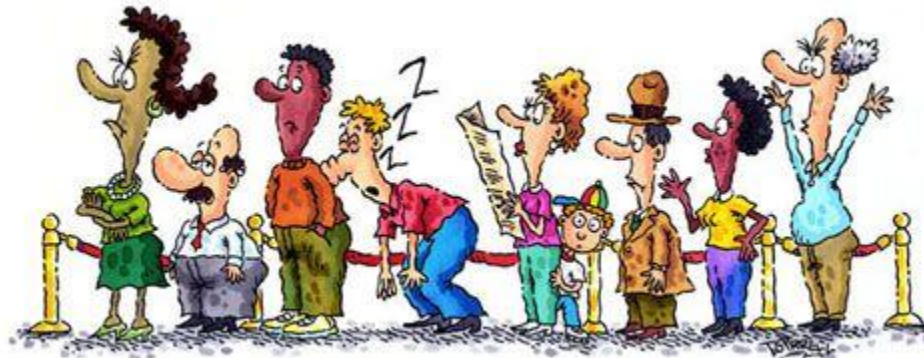



**VOTER'S AFFIDAVIT
REQUESTING TO VOTE IN PERSON AT THE POLLS AFTER
FAILING TO RECEIVE MAILED ABSENTEE BALLOT**

(PRE-5)

State Form 55876 (R / 10-15)
Indiana Election Division (IC 3-11-10-31; 3-11.5-4-18(c))

INSTRUCTIONS: A voter who requested that an absentee ballot be mailed to the voter, but has not received the absentee ballot by election day, may vote in person at the polls upon executing this affidavit.

STATE OF INDIANA)
)
COUNTY OF _____)
) SS:
TOWNSHIP OR WARD _____)
)
PRECINCT _____)

**VOTER'S AFFIDAVIT
REQUESTING TO VOTE IN PERSON AT POLLS
AFTER FAILING TO RECEIVE MAILED
ABSENTEE BALLOT**

I, the undersigned, do solemnly swear all of the following:

- (1) I filed an application with the county election board (or county board of elections and registration) requesting that an absentee ballot be mailed to me for the election to be conducted today.
- (2) As of today, I have not received the absentee ballot requested in my application.
- (3) I request that I be permitted to vote in person at the polls in this election.

Signature of Voter

Printed Name of Voter

**SUBSCRIBED AND SWORN TO BEFORE ME, THE DULY ACTING _____ (insert title of
precinct election official or vote center official) OF THIS PRECINCT, ON THIS
THE _____ DAY OF _____, 20__.**

Signature of Precinct Election Official
(or Vote Center Official)

Printed Name of Precinct Election Official
(or Vote Center Official)

*If ballot was
never received.*

The Lake County Board
of Elections and Registration
2293 North Main Street, A-205
Crown Point, IN 46307-1854

© GCU 1049-M

This envelope contains blank absent voter's ballot (ABS-8)
for the Primary General or Municipal Special Election
(Insert date of election) **May 5, 2026**
and if not called for or delivered within 5 days, return to sender.

POSTAGE
STAMP HERE
(AT LEAST FIRST
CLASS MAIL)

Surrendered

**NOTE! ALL MATERIALS ENCLOSED IN THE BALLOT
ENVELOPE MUST BE SURRENDERED!**

If they have the Physical Ballot, no Pre-5 is required. You will take the Ballot, allow the voter to vote, and return the Surrendered Ballot with election supplies.

Fail-Safe Procedures

What is a fail-safe procedure?

- ✓ Fail safes are procedures in place to help resolve voter eligibility issues at the polls.
- ✓ In Indiana, we try everything before issuing a provisional ballot.
- ✓ **No one is ever turned away from the polls without the ability to vote at least a Provisional Ballot.**

Poll Worker should:

- 1. Call the County Election Board for a potential Certificate of Error or a Miscellaneous Error.**
 - ✓ If the voter's name is not on the POLL-PAD due to a county error, write information on the Poll-Pad Errors sheet, which is on the very last page of the Forms Book.
- 2. EMERGENCY LIST OF VOTERS**
- 3. Use the VRG-4/12 Form**
 - ✓ If the voter has moved outside of the precinct but reside within the county.

WHEN A CHALLENGE SHOULD BE ISSUED

It is against the law...

1. For a person who is not eligible to vote in the precinct to attempt to cast a ballot.
2. For a precinct election official to knowingly fail to challenge an ineligible person.
3. For a precinct election official to challenge a voter that the official knows is eligible to vote.

WHO MAY CHALLENGE A VOTER?

1. Member of the Precinct Election Board (*Inspector, Judge, and Clerk*).
2. A poll clerk only based on questionable signatures.
3. What form to use? PRE-4
4. During a Primary Election a voter who is a member of the Political party whose ballot is being Challenged by the voter (pre-6)

Inspectors

- IF YOU USE ANY PROVISIONAL BALLOTS OR EMERGENCY BALLOTS (**THE USE OF EMERGENCY BALLOTS REQUIRES PERMISSION! YOU MUST CALL 219-755-3795**)
- YOU NEED TO SHOW THAT YOU USED THEM BY MARKING ENVELOPE #1 (WHITE ENVELOPE) WHERE INDICATED

ENVELOPE NO. 1

DO NOT SEAL THIS ENVELOPE

TO THE INSPECTOR: Enclose in this Envelope, tally cards and tally tapes, start and vote cards. Fill in the spaces below and have the Precinct Election Board sign officially, and deliver to the Director of the Lake County Board of Elections and Registration with the other returns.

For complete step by step instructions on closing your voting machine refer to the Infinity Folder for your complete check-off list.

*Please verify the serial number on the machine and on the tally cards prior to tallying your machine.

*Use ONE tally card per voting machine.

**THIS ENVELOPE CONTAINS
INFINITY TALLY MATERIALS**

ZIP LOCK BAG CONTAINING _____ Tally Card(s) Only!
_____ Start Card _____ Vote Card (s) _____ (Tuesday Zero Proof tape) _____ Tally Tape (s)

Lake County, Indiana

I hereby certify that Emergency Ballots were used: _____ Yes _____ No

I hereby certify that Provisional Ballots were used: _____ Yes _____ No

I hereby certify that all VOTING MACHINES PROVIDED were used: _____ Yes _____ No

IF NO, I hereby certify the following VOTING MACHINES were not used and the reason why:

Machines/Reason: _____

Attest:

Inspector

Clerk

Precinct
Election
Board

Judge

Clerk

Judge



What Provisional supplies go to the precinct?

1. SEALED RED PROVISIONAL BAG
2. INSIDE BAG:
 - A. FORM BOOK
 - B. SECRECY ENVELOPES
 - C. BALLOT CARDS
 - D. OFFICIAL BALLOT
 - E. PRE-4 – PRO-2 ENVELOPE

Only break the Seal if you intend to use a Provisional Ballot.



CHALLENGE AFFIDAVIT OF A VOTER BY A CHALLENGER OR MEMBER OF THE PRECINCT ELECTION BOARD / AFFIDAVIT OF A CHALLENGED VOTER
 State Form 42132 (R14 / 3-22)
 Indiana Election Division (IC 3-11-8-21; 3-11-8-23.5; 3-11.5-4-13.5; 3-11.5-4-13.6)

(PRE-4)

Is this an absentee ballot? Yes No

INSTRUCTIONS: After the challenger completes this side of the form, the challenged voter may complete the second page of this form. If the challenged voter does so, the challenged voter is entitled to cast a provisional ballot. Do not use this form to challenge a voter at a primary election due to the voter's party affiliation. Use PRE-6 form instead.
NOTE: THIS FORM MUST BE PRINTED DIRECTLY ON THE PRO-2 PROVISIONAL BALLOT SECURITY ENVELOPE.

STATE OF INDIANA, COUNTY OF _____

GENERAL INFORMATION

I, the undersigned, believe that _____, now offering to vote, is not a legal voter in this precinct, for the following reason(s):
 (insert name of voter.)

- Voter Eligibility – Fail Safe Procedures**
- This voter's name is not included on the poll list, and is **NOT** entitled to vote by using a "Fail Safe" procedure.
 - This voter's name is included on the poll list, but this voter does not currently reside in the precinct, and is **NOT** entitled to vote in this precinct by completing a VRG-4/12 form or a VRG-15 form, or other "Fail Safe" procedure.

- Voter Identification**
- This voter was unable or declined to present proof of identification when required by law to do so.
 - This voter is identified on the poll list as required to present an additional document that confirms the voter's identity and current residence address, but has not done so.

- Voter Eligibility - General Requirements**
- This voter is not a U.S. citizen.
 - This voter will not be eighteen (18) years of age or older at the general election.
 - This voter's signature on the election day poll list does not match the signature on the voter's registration record.
 - This voter's signature on the absentee ballot security envelope affidavit is missing or does not match the signature on the voter's absentee ballot application, electronic poll book registration record maintained in the statewide voter registration system.
 - Other _____
 (insert specific reason for challenging voter.)
- I obtained the information from _____
 (insert name of person(s) supplying information for challenge.)

CHALLENGER AFFIRMATION

I swear (or affirm) that the foregoing statements are true, to the best of my knowledge and belief, and understand that making a false statement on this affidavit is punishable under the penalties of perjury.

Signature of challenger	Printed name	If serving as precinct officer: <input type="checkbox"/> Inspector <input type="checkbox"/> Judge <input type="checkbox"/> Poll Clerk
Precinct	Township or ward	City or town

AFFIRMATION OF AFFIDAVIT

STATE OF _____)
)
 COUNTY OF _____)
)
 I swear (or affirm) that the above challenge affidavit of a voter was subscribed and sworn to before me this _____ day of _____, 20____.

Signature of Official Administering Oath (Inspector, Judge, Poll Clerk, Sheriff, or Absentee Board Member Other than Challenger above) _____ Printed Name and Title _____

AFFIDAVIT OF A CHALLENGED VOTER

STATE OF INDIANA, COUNTY OF _____

GENERAL INFORMATION

- I, the undersigned, state the following:
- that I am a citizen of the United States.
 - that my date of birth is _____ (mm/dd/yy) to the best of my information and belief.
 - that I have been a bona fide resident of this precinct for thirty (30) days immediately before this election or I am qualified to vote in this precinct under IC 3-10-10, IC 3-10-11.
 - that I am generally known by the name in which I desire to vote, which is _____.
 - that I have not voted and will not vote in any other precinct in this election.
 - that my present residence address is _____
 (and, if applicable, my residence address thirty (30) days before this election was at: _____)
 I moved to my residence address in this precinct on the following date: _____ (mm/dd/yy)
 - that, if applicable, if I was challenged under boxes 3 or 4 on the Affidavit of a Voter By a Challenger portion of this form, I did present proof of identification or additional documentation that complied with IC 3-5-2-40.5 or IC 3-7-33-4.5.

CHALLENGED VOTER AFFIRMATION

I swear (or affirm) that the foregoing statements are true, to the best of my knowledge and belief, and understand that making a false statement on this affidavit is punishable under the penalties of perjury.

Signature of challenged voter	Printed name
Precinct	Township or ward City or town

AFFIRMATION OF AFFIDAVIT

STATE OF _____)
)
 COUNTY OF _____)
)
 I swear (or affirm) that the above challenge affidavit of a voter was subscribed and sworn to before me this _____ day of _____, 20____.

Signature of Official Administering Oath (Inspector, Judge, Poll Clerk, Sheriff, or Absentee Board Member Other than Challenger above) _____ Printed Name and Title _____

PRE-4/PRO-2 ENVELOPE

1. PERSON CHALLENGING COMPLETES TOP PORTION OF PRE-4 (USUALLY INSPECTOR OR CLERK)

2. CHALLENGED VOTER COMPLETES BOTTOM

3. It is Mandatory that BOTH CLERKS **MUST** INITIAL THE BACK OF THE PROVISION BALLOT CARD AND SECRECY ENVELOPE OR VOTE WILL NOT COUNT.

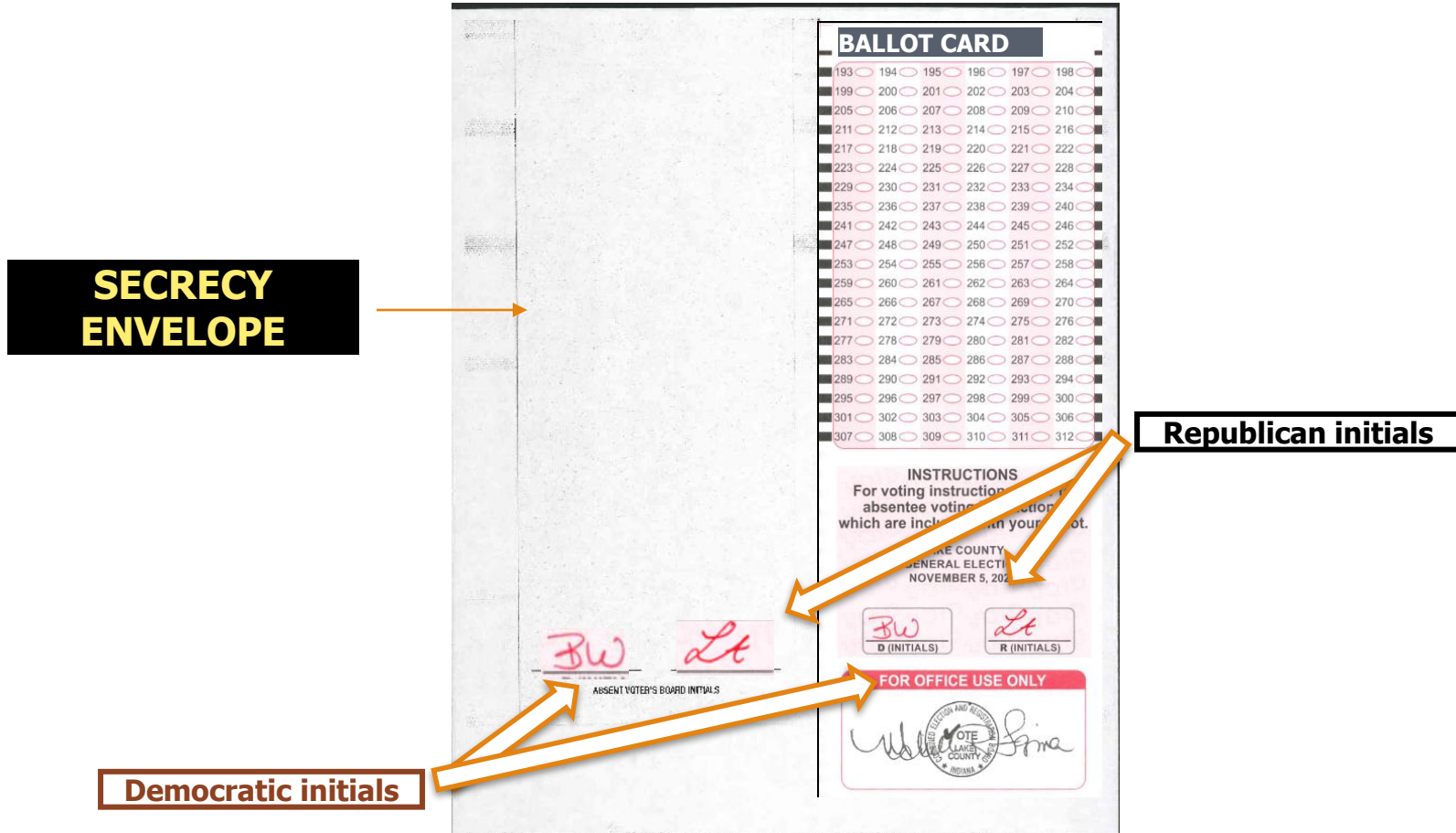

4. GIVE THE VOTER THE PROVISIONAL BALLOT CARD, OFFICIAL BALLOT, SECRECY ENVELOPE AND THE SECURITY ENVELOPE (PRO-2/PRE-4).

Failure to do this step will cause the ballot to be rejected.



PROVISIONAL BALLOT SECURITY ENVELOPE

Part of State Form 42132 (R14 / 3-22)
Indiana Election Division (IC 3-11.7-1-8; 3-11.7-5-3; 3-11.5-4-13.5; 3-11.5-4-13.6)

(PRO-2)

TO THE VOTER

READ CAREFULLY AND FOLLOW THE INSTRUCTIONS BELOW.

STATE OF INDIANA)
)
COUNTY OF _____)

I, *(Print your name and address below.)*

Name of Voter: _____

Residence Address of Voter *(number and street, city, state, and ZIP code):*

Telephone number *(optional)*: (_____) _____ - _____

have cast the enclosed provisional ballot at Precinct Name: _____

at the *(select one)* PRIMARY GENERAL MUNICIPAL SPECIAL ELECTION

to be held on:

_____ *(Insert date (mm/dd/yy) of election.)*

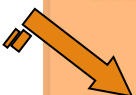

Signature of voter

Date signed *(mm/dd/yy)*

_____/_____/_____

COUNTY ELECTION BOARD FINDINGS

NOTE: Absentee voters voting by mail or traveling board do not complete PRO-2 because the application serves as the voter's response to the challenge.

The enclosed provisional ballot is determined to be:

Valid
 Invalid due to the following reason: _____

If invalid, this envelope may not be opened, and this ballot may not be counted.

Dated *(mm/dd/yy)*: _____

County Election Board

TO THE PROVISIONAL BALLOT COUNTERS: After the ballot has been found valid by the county election board, open this envelope carefully. Do not deface or destroy the affidavit or the envelope. Take out the ballot enclosed for processing. If the ballot does not contain the initials of the poll clerks, the ballot shall, without being unfolded to disclose how the ballot is marked, be endorsed with the word "Rejected" and enclosed in State Form PRO-7 envelope.

5. VOTER MARKS
BALLOT IN SECRET
AND SEALS BALLOT
IN PRO-2/PRE-4
ENVELOPE.

6. THE VOTER
COMPLETES PRO-2
SIDE OF ENVELOPE.

7. INSPECTOR GIVES THE VOTER
THE PRO-9, WHICH CONTAINS
COUNTY CONTACT
INFORMATION
AND EXPLAINS PROVISIONAL
BALLOT FOLLOW-UP INFO.

BEFORE VOTING

VRG 4/12 FORM

IF THE VOTER INFORMS THE CLERK THAT THEY HAVE MOVED, the voter then must complete a VRG 4/12 FORM. The voter can vote one last time in their old precinct. As long as they remain within the same county.



AFFIDAVIT OF REQUEST TO UPDATE VOTER REGISTRATION AT THE TIME OF REQUESTING A BALLOT

(VRG 4/12)

State Form 28166 (R16 / 8-23)
INDIANA ELECTION DIVISION (IC 3-7-39-7; 3-7-48-5; 3-10-1-24; 3-10-11-6; 3-10-12-3.4)

INSTRUCTIONS

Questions regarding when to use this form should be directed to the County Election Board at LAKE (insert telephone number.)
A description of the voters eligible to vote using this form is on the reverse side. A voter must complete and sign this form in front of a notary or other person authorized to administer oaths, which includes an Election Day precinct election officer, or before Election Day, an absentee voter board member. Alternatively, if Box 2, 3, 4 or 5 apply, the voter is permitted to make an oral affirmation to the poll workers or absentee voter board members, who will then record the voter's affirmation and initial below in the box designated for the voter to sign.

VOTER AFFIRMATION

To be eligible to vote using this form, a voter must make one of the affirmations below. To the County Election Board, Precinct Election Board, or Absentee Voter Board of LAKE County: I, the undersigned, affirm that the information on this affidavit is true and complete, to the best of my knowledge. I am eligible to vote in this precinct as indicated above: (you must check either Box 1, 2, 3, 4, or 5)

- BOX 1: I changed my residence from one (1) precinct to another within Indiana less than 30 days before the primary/general/special election held on the _____ day of _____, 20____; OR
- BOX 2: I changed my residence from one (1) precinct to another within the same county and within the same congressional district before the primary/general/special election held on the _____ day of _____, 20____; OR
- BOX 3: In a county using an electronic poll book, I changed my residence from one (1) address to another address within the same precinct; OR
- BOX 4: In a county using an electronic poll book, I changed my name and desire to update my voter registration record; OR
- BOX 5: I still reside at the address indicated on my cancelled voter registration record despite the county indicating that I moved from my residence.

VOTER'S NAME, DATE OF BIRTH, VOTER IDENTIFICATION NUMBER AND TELEPHONE NUMBER

Last Name		First Name		Middle Name	Precinct
Date of Birth (mm/dd/yyyy)		Voter Identification Number			Telephone Number (optional)
		<small>(Indiana issued driver's license number, OR state identification number, OR if voter does not possess driver's license, provide last 4 digits of social security number, OR state NONE if voter does not possess any of these documents)</small>			()
Are you a citizen of the United States of America? <input type="checkbox"/> Yes <input type="checkbox"/> No			Will you be at least eighteen (18) years of age on or before election day? <input type="checkbox"/> Yes <input type="checkbox"/> No		

VOTER'S PREVIOUS NAME (If voter's name has changed, complete this section with the voter's name before the voter changed it.)

Last Name		First Name		Middle Name
-----------	--	------------	--	-------------

VOTER'S PREVIOUS RESIDENCE ADDRESS (If voter checked BOX 1, 2, or 3 above)

Street Address	City / Town	State	ZIP Code	County
		IN		

VOTER'S CURRENT RESIDENCE ADDRESS (If voter checked BOX 1, 2, or 3 above)

Address instructions: If residing in a city or town, write the street address and any apartment or room number. If not residing in a city or town, write the mailing address and the nearest streets or roads if not included. Example: "100 Maple Street, Apt. 12, Anytown, IN" or "R.R. 5, Box 12 Friendscribble Road and County Road 100 North, Anytown, IN."

Street Address	City / Town	State	ZIP Code	County
		IN		

VOTER'S CURRENT MAILING ADDRESS (If different from residence address)

Street Address	City / Town	State	ZIP Code	County
		IN		

By filing this affidavit, I am requesting that my registration be updated to my new name or the residence address where I now reside as indicated above (If I changed residence to another precinct in the same county) as soon as the update is permitted. If I have changed residence from one county to another county in Indiana, I request that my registration in the county where I formerly resided be cancelled under IC 3-7-43-4. I understand that making a false statement on this affidavit is punishable under the penalties of perjury.

NOTE: This must be subscribed and sworn to before a person authorized to administer oaths within Indiana, such as a notary public, judge, clerk of the circuit court, member of a board of voter registration, precinct election officer, or absentee voter board member.

Signature of Voter (or initials of poll clerks witnessing oral affirmation if Box 2, 3, 4 or 5 applies)	Printed Name
---	--------------

Subscribed and sworn to before me, this _____ day of _____, 20_____.

My commission expires (mm/dd/yyyy): _____ County of Residence: _____ (Not required if absentee board member or precinct election officer)

Signature of Person Administering Oath	Printed Name	Title
--	--------------	-------

Certificates of Error (C O F E)

ERROR BY COUNTY OFFICE

If the voter's name is not on the Poll Pad or the Registered Voter List, call the County Election Board at 219-755-3795

VOTER'S POLL LIST

2026 PRIMARY ELECTION

Lake County

Precinct

Name of Voter	Signature of Voter	Address of Voter	DOB	Voter ID number	Voter ID number Type	Certificate of Error or Provisional Ballot Information
---------------	--------------------	------------------	-----	-----------------	----------------------	--



**DO NOT SIGN ON THIS PAGE!!! CALL
OUR OFFICE FIRST 219-755-3795**



EMERGENCY BALLOTS ARE ONLY USED FOR COMPLETE AND TOTAL MACHINE FAILURE, NOT BECAUSE OF LONG LINES.

CALL OFFICE FOR AUTHORIZATION TO USE EMERGENCY BALLOTS, AUTHORIZATION NUMBER MUST BE WRITTEN ON ENVELOPE #8.

POLL CLOSING REMINDERS

REMEMBER, ANY VOTER IN LINE AT 6:00 P.M. SHALL BE ALLOWED TO VOTE.

ONCE EVERYONE HAS VOTED AND LEFT THE POLLS:

Follow the checklist in the Election Day Handbook.

IMPORTANT REMINDERS:

1. Machines must be tallied.
2. No precincts can tally machines until all voters have left the building. Be sure to tally each machine separately, using a new red tally card for each machine.
3. All machines must be returned to their original delivery position.
4. All ADA signs and equipment are to be placed by the machine. DO NOT BRING ADA OR MACHINES TO THE DROP-OFF SITES UNLESS SPECIFICALLY INSTRUCTED.
5. Polling places must be returned to their original setup. Leave the Building as you found it.
6. The Inspector must return all election supplies to the drop-off sites with Judge of the opposite party.

YOU WILL NEED A SEPARATE RED TALLY CARD AND ENVELOPE FOR EVERY VOTING MACHINE YOU HAVE IN YOUR PRECINCT



LABELLED WITH INDIVIDUAL
MACHINE NUMBER ON BACK
OF CARD

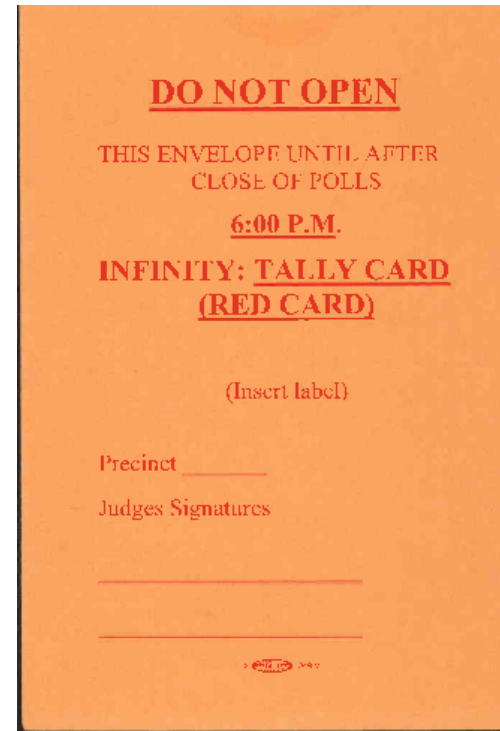

LABELLED WITH ALL MACHINE NUMBERS
FOR YOUR PRECINCT

REMEMBER



Set a numbered red tally card that corresponds to each numbered voting machine to avoid using the same card twice.

DROP OFF SITES

Gov't Complex A-2nd Fl.,

Saint John – Hobart – Lake Station – Winfield – Tri-Creek
Crown Point – Schererville – Merrillville – Cedar Lake
Eagle Creek - West Creek

Gary Airport-West Entrance (B Coleman Aviation)

Gary – East Chicago - Whiting

Wicker Park (SOCIAL CENTER)

Hammond – Highland – Dyer – Munster-
Griffith

DROP OFF LOCATION

BE PREPARED

Inspectors, please have these items ready for drop off:

1. Envelope #1 with Zero Proof tape, Start card, Vote cards & tally tapes inside. Also, inserted is a Ziplock bag containing the Red Machine Tally cards only. Check Mark if Emergency, Provisional ballots and all voting machine were used.
2. POLL PAD AND JETPACK/CRADLEPOINT IN THEIR BOXES THE WAY YOU RECEIVED THEM.
3. STATEMENT OF EXPENSE.
4. Emergency Ballot Envelope #8 if used.
5. Red Provisional Bag, if used.

I do solemnly swear or affirm :

1. I will support the Constitution of the United States and the Constitution of the State of Indiana
2. I will faithfully and impartially discharge the duties of inspector, judge, or poll clerk of this precinct under the law.
3. I will not knowingly permit any person to vote who is not qualified and will not knowingly refuse the vote of any qualified voter or cause any delay to any person offering to vote other than is necessary to procure satisfactory information on the qualification of that person as a voter.
4. I am now a bona fide resident of the county in which the precinct in which I am to act as a member of the election board is situated and, if required by law, am a qualified voter of that county.
5. I will not disclose or communicate to any person how any voter has voted in this election or how any ballot has been folded or marked.
6. I am able to read, write, and speak the English language.
7. I have no property bet or wagered on the result of this election.
8. I am not a candidate to be voted for at this election in this precinct, except as an unopposed candidate for a political party office.
9. If I am serving as an inspector, I am not the chairman or treasurer of the committee of a candidate whose name appears on the ballot.
10. I am not related to any person to be voted for at this election in this precinct as the spouse, parent, father-in-law, mother-in-law, child, son-in-law, daughter-in-law, grandparent, grandchild, brother, sister, brother-in-law, sister-in-law, uncle, aunt, nephew, or niece that person, unless that person is an unopposed candidate.
11. I was trained as required by 1C 3-6-6-40.



We can help!

LAKE COUNTY BOARD OF
ELECTIONS AND REGISTRATION

2293 N MAIN STREET

CROWN POINT, IN 46307

219-755-3795 & 219-755-3796